

Drive Unit for Heavy Tasks

HPXdrive Heavy Duty

The **HPXdrive Heavy Duty** is a powerful version for difficult tasks. The advantages of the **HPXdrive**-technology – the constant high closing force and the compact design – guarantee a long life and reliability.

The standard rotator of the **HPXdrive Heavy Duty** is the **KINSHOFER** rotator with flange KM 04 F140-30V. In case a quick change to a non-rotating hook is necessary, the **HPXdrive** can be delivered with the **KINSHOFER** shaft rotator KM 04 S in combination with the quick change system KM 505 or the reduction link KM 502.

Technical Information HPXdrive Heavy Duty:

Torque (at 32 MPa):	21000 Nm
Operating pressure:	26 - 32 MPa (approx. 260 - 320 bar)
Pump capacity:	40 - 90 l/min

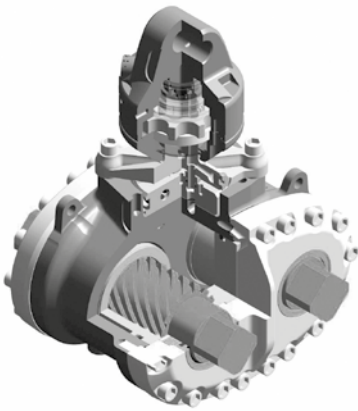
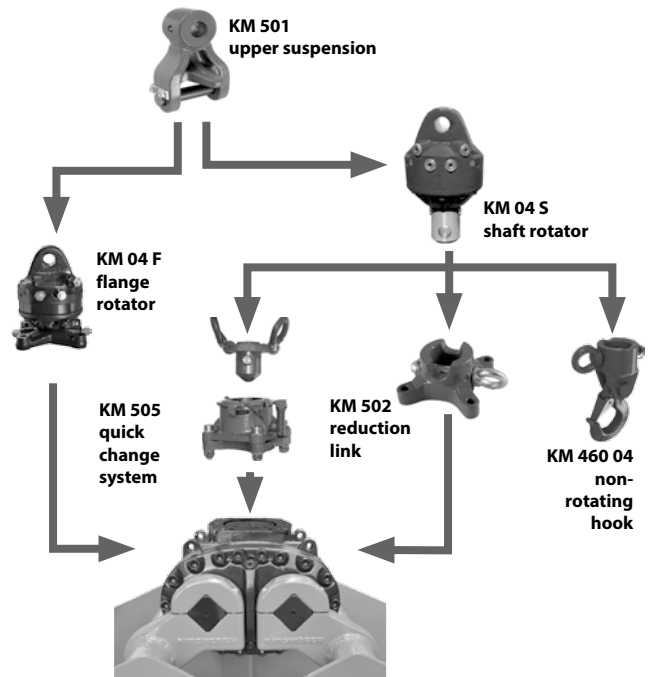

HPXdrive Heavy Duty with Flange Rotator HPX-HD-04F-30V

Package consists of: upper suspension KM 501 4500, rotator KM 04 F140-30V, drive unit **HPXdrive Heavy Duty** with non-return valve

Self weight: 195 kg

Height: 510 mm

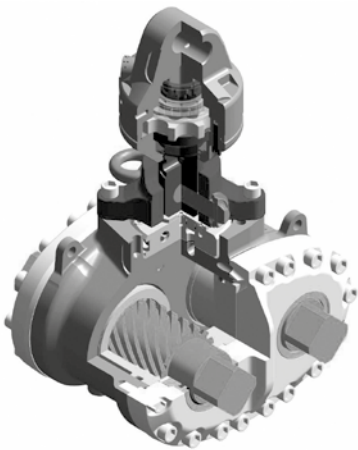

HPXdrive Heavy Duty/502 with Shaft Rotator and Reduction Link HPX-HD-502

Package consists of: upper suspension KM 501 4500, rotator KM 04 S, reduction link KM 502 4500, short connecting hoses KM 203 01, drive unit **HPXdrive Heavy Duty** with non-return valve

Self weight: 200 kg

Height: 565 mm

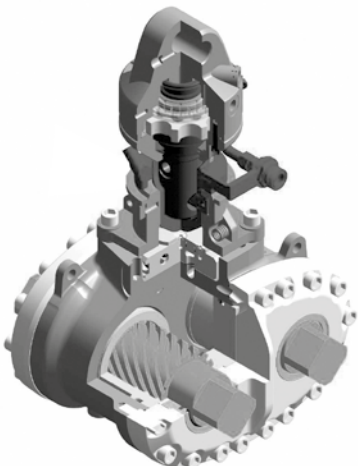

HPXdrive Heavy Duty/505 with Shaft Rotator and Quick Change System HPX-HD-505

Package consists of: upper suspension KM 501 4500, rotator KM 04 S, quick change system KM 505, short connecting hoses KM 203 01, drive unit **HPXdrive Heavy Duty** with non-return valve

Self weight: 170 kg

Height: 575 mm

Note: for heavy duty tasks we recommend the quick change system KM 505 HD in combination with KM 04 S68-30US

Please note: The drive unit **HPXdrive Standard** can only be used in combination with **KINSHOFER** Rotator and **KINSHOFER** Shells

HPXdrive Heavy Duty Shells

Exchangeable Shells

The bucket shells of the **HPXdrive Heavy Duty** are bolted to the shafts, and therefore it is very easy to replace them with another set of shells. Different types of shells for different applications can be refitted onto the driving unit, e.g. clamshell bucket, rock grapple, timber grapple, hay and forestry grapple. Other types of shells are available on request.

The interchangeable shells are delivered with an exchange aid that guarantees the **HPXdrive Heavy Duty** can be positioned with ease.

Package consists of: exchangeable shells, bolt-on teeth (for KM 605HPX), exchange aid kit

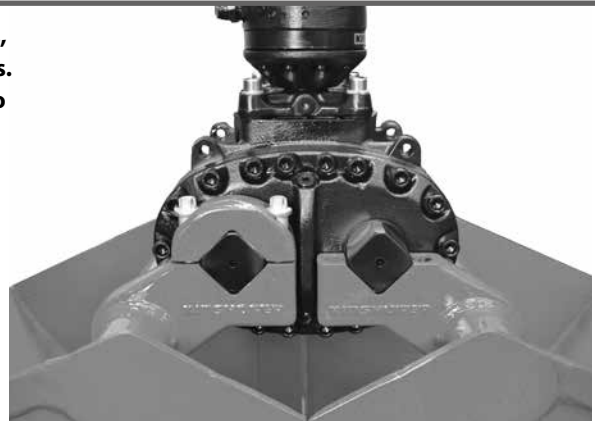

Type	Volume (litre)	Width (mm)	max. Opening (mm)	Number of teeth/tines	Self weight (kg)
Shells for Heavy Duty Clamshell Bucket – KM 605HPX					
KM 605HPX-200S	200	400	1420	4	140
KM 605HPX-250S	250	500	1420	4	170
KM 605HPX-350S	350	650	1420	6	200
KM 605HPX-450S	450	800	1420	6	225
KM 605HPX-550S	550	1000	1420	8	265



Shells for Heavy Duty Clamshell Bucket with Open Shells – KM 605U HPX					
KM 605U HPX-300S	300	670	1545	5 *	240
KM 605U HPX-400S	400	820	1545	7 *	260
KM 605U HPX-450S	450	920	1545	7 *	275
KM 605U HPX-500S	500	1020	1545	9 *	295

* optional available with bolt-on teeth (weight w/o teeth)



Shells for Heavy Duty Clamshell Bucket with Open Shells – KM 605U HPX-Z					
KM 605U HPX-Z-400S	400	820	1545	-	275
KM 605U HPX-Z-450S	450	920	1545	-	285
KM 605U HPX-Z-500S	500	1020	1545	-	300
KM 605U HPX-Z-600S	600	1220	1545	-	335



Shells for Heavy Duty Rock Grapple – KM 613HPX-HD					
KM 613HPX-HD-0,35S	0,35 m ²	400	1705	-	135



Shells for Heavy Duty Timber Grapple – KM 632HPX-HD					
KM 632HPX-HD-0,16S	0,16 m ²	400	1290	-	90



Shells for Heavy Duty Hay and Forestry Grapple – KM 641HPX-HD					
KM 641HPX-HD-0,4S	0,40 m ²	940	1720	7	195

Please note: The drive unit **HPXdrive Heavy Duty** can only be used in combination with **KINSHOFER** Rotator and **KINSHOFER** Shells